

Marrickville Town Hall

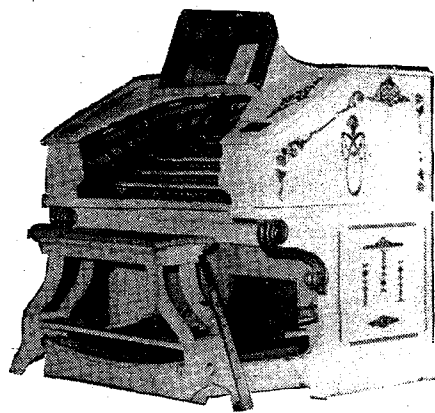

Orion Centre Campsie

MAY 1988

T
O
S
A

N
E
W
S

A Musical Afternoon

Featuring

John Atwell

on TOSA's
magnificent Theatre Pipe Organ

SUNDAY 29th. MAY 1988 AT 2.00PM.



JOHN ATWELL

ASSOCIATE ARTIST



MARK WALTON
SAXOPHONIST

VOLUME 27

ISSUE 5

PRICE \$1.00

The Official Publication of the Theatre Organ Society
of Australia, N.S.W. Division, Inc.
Address - Box 474 Sutherland 2232
Registered by Australia Post - Publication No. N.B.H. 1038

DIRECTORY**THEATRE ORGAN SOCIETY OF AUSTRALIA (N.S.W.DIVISION) INC.****PATRON** Ian Davies**PRESIDENT** Phyllis Wilson (759 6050)**VICE PRESIDENTS** Cliff Bingham (476 2363) John Shaw (759 5825)**SECRETARY** Bob McMinn (542 3937)**ASSISTANT SECRETARY** Pam McMinn (542 3937)**TREASURER** John Rattray (750 3779)**ASSISTANT TREASURER** Murray Ries (750 3779)**MEMBERSHIP SECRETARY** Bob McMinn (542 3937)**RESEARCH AND ARCHIVES** Ian Cameron (048 41 1616)**PRACTICE CONVENOR** Bob Staunton (607 8925)**COMMITTEE** Bill Schumacher, Neil Palmer, Ron Wilson, Jack Lawson
Margaret Hall, Merv Palmer**MINUTE SECRETARY** Murray Ries (750 3779)**TOSA EDITOR** Ron Wilson (759 6050)**TOSA NEWS PRINTING** Ron Wilson**PHOTOGRAPHY** Barry Tooker**CONCERT RECORDING** Bill Schumacher and Ron Wilson**CONCERT TAPE HIRING** Neil Palmer (798 6742)**CONCERT TICKET BOOKINGS** Merv Palmer (798 6742)**PROMOTION OFFICER** Kevin RolandsAddress all correspondence to:-
The Secretary, T.O.S.A. (N.S.W. Division) Inc.
Box 474 P.O. Sutherland N.S.W. 2232.**GARAGE SALE - TRADING POST**

A garage sale will be held at 153A Haldon Street Lakemba on Saturday 4th June at the residence of John Rattray and Murray Ries between the hours of 9.00am. and 3.00pm.

This will be a great opportunity for members and their friends to dispose of those unwanted goods you no longer have use for. John and Murray have a huge double garage, which fronts onto the footpath of a very busy street, resulting in good passing traffic.

Before submitting your item or items for sale, please fix a price on the article. If you have any queries, please ring John or Murray on 750 3779 (A.H.).

All proceeds from the afternoon sales will go towards the installation of the organ into the Orion Centre at Campsie.

**THANK YOU FROM FRANK**

I wish to say thank you very sincerely to all my good friends who were kind enough to express their concern and good wishes to me in so many ways during my recent illness and surgery.

It is wonderful to be over the operation, a successful double by-pass and to be regaining strength again.

Your phone calls, cards, visits, your kind thoughts and support were very warmly appreciated by both Edith and myself.

Frank Rohanek.

NEW MEMBERS

The Executive Committee extend a warm welcome to the following new members. We look forward to meeting you at our coming functions.

K.M. Bailey, John & Irene Quinn
Myra Synold.

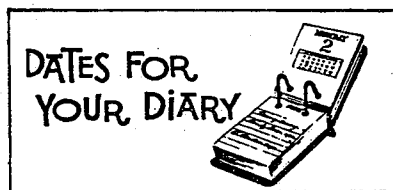
**MAY**

- Monday 2 7.30pm. **COMMITTEE MEETING**
- Wednesday 11 8.00pm. **CLUB NIGHT - QUARTERLY MEETING**
MARRICKVILLE TOWN HALL
 Featured organist for the evening will be Don Stagg from the U.S.A.
- Also we will be showing videos of Phil Kelsall, from Blackpool Tower Ballroom fame. An interesting video of the decline and re-awakening of the cinema organ in Great Britain.
- Please bring a plate to share for supper.
- Sunday 29 2.00pm. **JOHN ATWELL and MARK WALTON** in concert
MARRICKVILLE TOWN HALL. Booking form in this issue.
PLEASE BOOK EARLY.

JUNE

- Saturday 4 9.00am. - 3.00pm. **GARAGE SALE - TRADING POST**
 To be held at the residence of John Rattray and Murray Ries.
 153A Haldon Street Lakemba. (Corner Haldon and Gillies Streets)
- Monday 6 7.30pm. **COMMITTEE MEETING**
- Sunday 26 2.00pm. **PAID CONCERT - MARRICKVILLE TOWN HALL**
FULL DETAILS IN NEXT ISSUE

JULY

- Monday 4 7.30pm. **COMMITTEE MEETING**
- Sunday 31 2.00pm. **PAID CONCERT - MARRICKVILLE TOWN HALL**
 Details in next months TOSA NEWS

AUGUST

- Saturday 20 8.00am. **3801 STEAM TRAIN TRIP**
 Depart Central station, stopping at Strathfield, arrive at Moss Vale where, during the two and half hour stop-over, lunch will be served. Travel down the mountain to Unanderra, returning to Sydney via Wollongong, stopping at Hurstville on return journey.
 Timetable when confirmed, will be published in the next issue.

COST:BOOKINGS BEFORE JUNE 30

Adults	\$30.00	Children 5-15	\$25.00
		(Includes lunch)	
Children under 4	- free	(Does not include lunch)	

BOOKINGS AFTER JUNE 30

Adults	\$35.00
Children 5-15	\$30.00
	(Includes lunch)

Party of 8 compartments can be booked. Booking form in this issue.
 For enquiries, phone John Rattray or Murray Ries on 750 3779. (AH).

STOP PRESS STOP PRESS STOP PRESS**HECTOR OLIVERA - LIVE FROM SYDNEY,
AUSTRALIA**

The committee has great pleasure in announcing the release of a double cassette of "HECTOR OLIVERA - LIVE FROM SYDNEY, AUSTRALIA, recorded at Marrickville Town Hall on Sunday 6th September 1987.

After listening to the master tape, Hector was delighted at the quality of the recording. After negotiations with Hector, which extended into the early hours of the morning, official approval was given to the society to produce a double cassette. Unfortunately, the wheels could not be put into motion until Hector had arrived back home and had a chance to listen to a copy of the concert tape so that he could make a decision on what numbers he wanted on the cassettes.

To professionally produce recordings involves a lot of work. If any material is used in a recording that was composed and published previously, a 'royalty' must be paid to the copyright owner of the material, which resulted in many hours of research. An organisation known as A.M.C.O.S. (Australian Mechanical Copyright Owners Society Ltd.) exists to simplify this otherwise time-consuming area. All that was required to do was to make a list of each item, giving its correct title, the name of the composer and the name of the publisher, if known. The next step was to prepare an edited master tape with three line-up tones, the exact running time of each side in minutes and seconds, including the gaps between items. Following on from this, a draft copy of the cassette insert had to be designed, formatted on a word-processor, (thanks to modern day technology) checked for any errors before submitting it for final printing.

The double cassette presentation box, which measures 5 1/2" x 4 1/4", (similar to a CD box) comes complete with full jacket notes including organ specification, Hector's biography and a large colour photo of Hector Olivera seated at the console.

The price for this double cassette is only:-

\$15.00

Postage in Australia \$1.50 - Overseas \$5.00

PLEASE NOTE:- The recording of Hector Olivera's concert **WILL NOT** be available from the tape library.

TAPE No.1**SIDE 1**

That's Entertainment
Thank Heaven for Little Girls
Scherzo (2nd Symphony) L. Vierne

I Don't Know How to Love Him

SIDE 2

Teddy Bear's Picnic
Over The Rainbow and Trolley Song

TAPE No.2**SIDE 3**

Sweet Georgia Brown
Moonlight Serenade
Tocatta of T. Dubois

SIDE 4

Waltz in Eb - Durand
Medley of Jerome Kern Compositions
 Make Believe
 Pick Yourself Up
 Old Man River
Symphonia (Cantata #29) - Bach

Concert was recorded live by the Theatre Organ Society of Australia (NSW Division) Inc. Sunday 6th September 1987 on the Wur-litzer Theatre Pipe Organ in Marrickville Town Hall, Sydney, N.S.W. Australia.

WANTED WANTED

The society urgently requires a 6ft. step ladder for maintenance in the organ chambers at Marrickville Town Hall. If any member has one that they have no further use for, or where the society can purchase same at a reasonable price, please ring Neil Palmer on 798 6742.

NEWS FROM THE U.S.A.

OREGON IS BIG ORGAN LAND

At the present time Oregon is an area of organ activity. Foremost is the planning underway for the 1988 ATOS National Convention which will be held in Portland, starting July 2 and running through July 6, plus Puget Sound Encore Day, July 7 in the Seattle/Tacoma area.

Several theatre organ installations are underway. In Salem, Rick and Clayton Parks are erecting a 3/13 Wurlitzer in the Elsinore Theatre. The original 3/13 Wurlitzer from the theatre is owned by Kirk Whitcomb. He first rebuilt it as a touring instrument and then installed it in Galith's Pit Pub, Carnation, Washington, where it is today.

In Portland, Dale Haskins has purchased the Bob White Theatre and has started building three chambers for the 4/33 Robert-Morton organ which was originally installed in the San Francisco Pantage/Orpheum Theatre on Market Street. "Chamber space is 24ft. high, 12ft. deep and overall 55ft. wide and will be all-glass showcased," Haskins said.

The 850-seat neighborhood house, built about 1924, was considered a showplace, but in 1955, it was gutted and modernised in very plain style and the orchestra pit was cemented over. Haskins does not plan to redecorate the theatre because it will be his private music studio. He is having a 16ft. by 8ft. by 10ft. new basement entry constructed for the 25 horse-power blower.

Three other projects are underway within the metropolitan area of Portland. Steve Durham is installing a 2/5 Robert/Morton hybrid in Troutdale. He is also building many of the percussions for the instrument.

In King City, John Olsen purchased Milt Keiffer's 2/7 residence Wurlitzer and is enlarging it to 11 ranks. The installation was started by Mike De-Sart and is being completed by Lorin Minear. It is expected to be playing by summer.

Kurtis McKnight, who is in his early twenties and plays at Uncle Milt's Pizza Parlor in Vancouver, Washington, had a small organ installed in an equally small apartment in Tigard. The place was so small the console took up most of the living room, and the kitchen housed pipework and the blower.

Since then he has moved and now has a home with a garage and his wife has the kitchen to herself!

Kurtis learned to build chests by actually doing it - and has whipped up ten chests. Organ traps can be viewed from his front window.

Also in the active end is Bob Ricketts, who is having a solid state relay put on his Wurlitzer. Gerry Duffy, who had a large electronics firm in Portland which he sold, built the new unit for Ricketts; he also built another unit for Uncle Milt's Pizza Parlor organ. Duffy has a three-manual organ in his home. It is also interesting to note that Ricketts is one of the pioneer residence theatre organ buffs, being among the first to install a theatre instrument in a home.

Portlander Bob Burke sold his 3/12 Wurlitzer to Don Seely, one of the Organ Grinder staff organists. Removed last fall, it is reported Seely will install the instrument in his parent's home.

Another organ installation is planned to serve two different purposes. It is a 2/5 Robert/Morton and will go into a building at Camp Emerald Forest near St. Helens, Oregon. The building will be divided - one side as a chapel, the other a skating rink, and the organ will be used for both. The console for this organ came from a theatre in Silverton, Oregon, chests and pipework from a theatre in Salt Lake City, Utah.

Mark Reed, who owns the 3/14 Kimball, originally installed in the Neptune Theatre, Seattle, has moved the instrument to a five-acre plot near Beaver Creek. It had been almost completely installed in two prior moves. Reed noted "third time is charm!" He builds and restores band organs as an avocation and is employed at Forestry Centre in Portland.

News source - ATOS International News.

WHAT A WAY TO SPEND EASTER (Leeton Reviewed)

To contemplate Easter without Theatre Organ Music is to a Theatre Organ buff like bread without water, without whiskey. However, 1988 was to be that way, The Na-

tional Convention is to be held over the Anzac weekend instead of Easter, so a few hardy interstaters and a lot of Leeton locals had their own mini convention as a part of the Easter Rice Bowl Festival in the lovely Murrumbidgee irrigation area town of Leeton.

Good Friday in Leeton was as different from chalk is to cheese, indeed the whole weekend in Leeton saw fine sunny weather with the daytime temperatures in the mid 20's and none of the liquid sunshine that beset those who stayed in Sydney.

On Friday night, some twelve or fourteen TOSA Victorian members including Kent Wilson, Vice President, Eric Wicks, VOX editor, Betty and John McKillen, long time committee members and many more were joined by the only two TOSA NSW representatives, yours truly and Pam and some twenty or so TOSA Leeton people for a very enjoyable dinner at the Riverina Motel. Those present were welcomed by TOSA Leeton President Margaret Sands and in turn by the Rice Festival Director and the shire president. Kent Wilson's response, on behalf of the visitors was appropriate and praised the Leeton Chapter for their organisation of what promised to be a good weekend. The food comprising, a three course dinner, the main course of which you cooked yourself on the indoor barby was excellent.

Eleven pm. Good Friday night, a time when most respectable people have retired for the night, saw some 20,000 people in and around the main street of Leeton. The reason, at 11.00pm. "The Auction" commenced. For weeks, all the locals had been saving their "Auction Dollars", received with each purchase at a local store and tonight was the night to spend them. At midnight, all the shops had opened, yes all the shops, Coles and Fosseys and all the locals. The town went mad with sale fever, your scribe even lashed out and bought ten new handkerchiefs in an effort to mop up this persistent "flue".

Saturday afternoon was marked by the street parade and the crowning of the Rice Princess. Your scribe was seen to be sitting in the gutter of the main street of Leeton, some would say that is where he belongs, to watch the procession. I was in good company, about 25,000 people saw the parade in a town of normally 6,500 people.

On Saturday night I saw Australia's answer to Reginald Foort and Reg Dixon all in one.

Promptly at 8.00pm. the Hammond organ arrived at the Bowling Club, on its special trolley, having travelled all the way from Melbourne, then came the tone cabinet and after about ten minutes to set it up came the music. That master of Australian ballroom dance music, Cyril Pearl, played waltz after foxtrot after quick-step for five hours solid, with one twenty minute break for supper.

About 100 people attended the dance and between Cyril's music, the pokies in the next room and the bar, we all had a thoroughly enjoyable night. The Leeton ladies provided supper and tea or coffee in the normal tradition.

During the entire weekend. I was seeing, in every shop window in Leeton, a poster advertising David Johnston appearing in "Rice Bubble". What sort of Johnno routine was this to be. Sunday night at the Leeton Roxy and we were to find out. The Leeton Roxy is one of those grand old country theatres of the twenties and thirties but it has a real distinction, it is one of the few that remain. Although I do not know the circumstances or the story behind it the Leeton Roxy is now owned in some sort of community form and is used by all number and manner of local groups, including the Leeton chapter of TOSA. The theatre boasts a Wurlitzer electronic organ and it was this instrument that David Johnston was to play on the Sunday evening.

The Johnno concert, like all Johnno concerts ranged from comedy to classic and back to comedy. We had a Charlie Chaplin movie, a W.C. Fields movie, so expertly accompanied by David, we had some of the Phantom of the Opera score and to highlight some of the synthesiser features of the Wurlitzer, David played some of that Under the Bridges of Paris type accordion music. David played two encores to finalise a very professional and well put together concert, a concert that was the highlight of an enjoyable quiet weekend in a lovely country setting.

The energetic Margaret Sands and her helpers are to be congratulated for their fine organisational ability demonstrated by the way in which they presented their first "LEETON WEEKEND".

Those of you who stayed in Sydney and suffered the rain, missed a great weekend.

Bob McMinn - Secretary.

INTERSTATE NEWS FROM

**RUNAWAY VOTE FOR INCORPORATION**

Members who attended the Special General Meeting at Brighton on Sunday 28 February, or who mailed postal or proxy votes, voted 50 to one in favour of the proposal that TOSA Victorian Division should become incorporated.

The motion was passed in a few minutes, after members Ted Badger, Neil Shilton and Des Lang had spoken briefly in support.

Only one of the 54 members present when the vote was taken voted against the motion. Of the 99 postal and proxy votes, 97 were in favour and two against, making the final tally 150 for and three against.

Bendigo Chapter is now about to take the steps necessary for incorporation, having considered its status as an independent autonomous body makes such action desirable, rather than rely on Victorian Division's incorporation to protect Bendigo members.

TOSA Western Victorian Division (Ballarat Theatre Organ Society) and TOSA Tasmanian Division are also proceeding with incorporation. This means that within a few months, all TOSA divisions will be incorporated.

PIT A PROBLEM FOR BALLARAT

Extensive restoration works at Ballarat's Memorial Theatre now under way, pose a serious threat to the effectiveness of TOSA Western Victoria's Compton organ installation.

The five stages of the project are estimated to cost a total of \$4.8 million, of which stage 1 now in progress will cost \$2.6 million, and covers alterations and refurbishing backstage, with the installation of plumbing, electrical and fire precautionary services. The problem for the Theatre Organ Society

is in stage 2, which includes constructing an orchestra pit 900mm deep across the top of the sound chutes and the Compton console lift. The Society considers this to be quite unnecessary. A conference with the project manager and sound engineer, at which the views of the society and organ builder George Stephens were clearly expressed, resulted in some minor changes to the plans, but the orchestra pit is still envisaged in stage 2 when funds are available.

REGENT LINK

The death occurred on 18 February of William E J Harrison, engineer and sculptor, of Murrumbeena, aged 85.

Bill Harrison's best known work, stared at by millions of people, especially children, over the past 50 years, are the farmer and miner which slide out of Geelong's T&G Building clock tower and strike the hours on a large bell mounted between them.

He also designed and supervised the manufacture of the bronze light fittings in Parliament House, Canberra, the original Regent and the Metro, Collins Street theatres in Melbourne.

When the Regent was burnt down in 1945, replicas of the original chandelier and smaller light fittings were cast from the original moulds, then still in existence.

News source..... March 'VOX'.

ORION REPORT - APRIL/MAY

Recent work on the project has seen the construction of the tops and bases of five new small size regulators for the Wurlitzer. These will be used to replace two that are missing from the original inventory of the Capitol organ and to also provide a better system of winding for offnote chests and percussions.

Leathering of these regulators will begin before Anzac weekend and should be completed within two weeks.

Other work has seen the completion of the Cathedral Chimes and Glockenspiel actions, and a number of the non-tuned percussions, such as the Bass Drum/ Kettle Drum, Crash Cymbal, Tap Cymbal and general toy counter.

New actions are being built for additional percussions and these are a Cymbal Roll and High Hat Cymbal.

Numerous shipments of parts have arrived from America and England and these items will be used to complete the restoration of the Wurlitzer console amongst other things.

Hardie Industries have come to the party with the supply of PVC piping for the winding up of the organ and for this we are very grateful. Sizes will range from 300mm (1 foot) diameter to 50mm diameter, and will require no need for any metal trunking at all. Work will begin very soon on the wind lines in the solo chamber.

Thanks as always go to my diligent assistant Doug Smith for his continued assistance and enthusiasm and especially to Rob Gliddon for his days off work and leave time spent working on the regulators.

Slowly but surely, we are getting there!!

John Parker - Organ Builder.

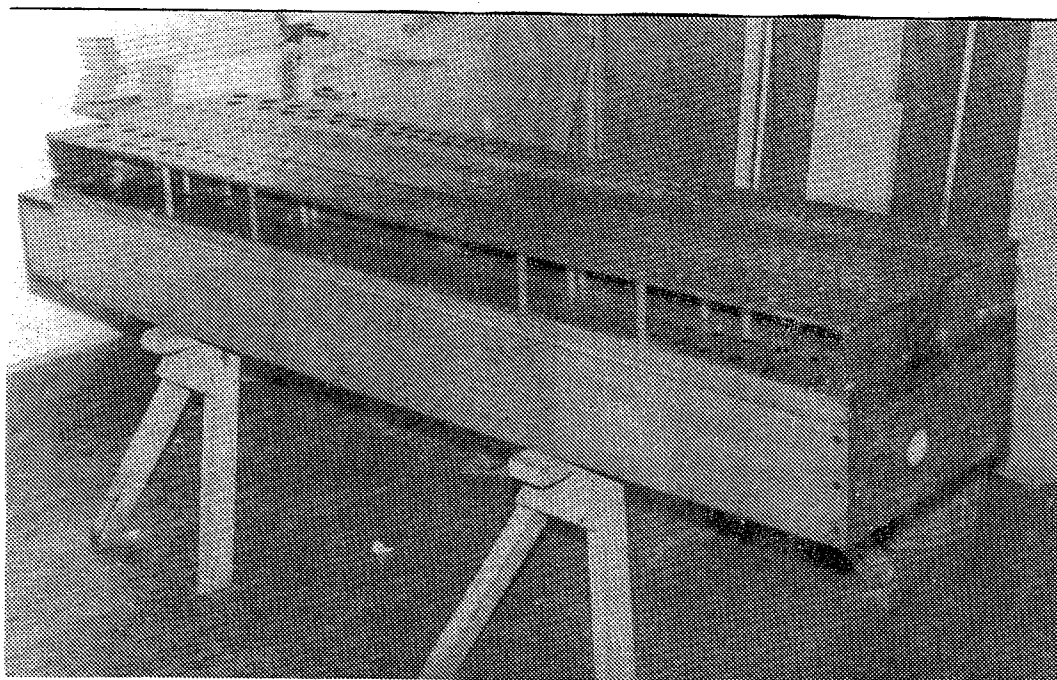
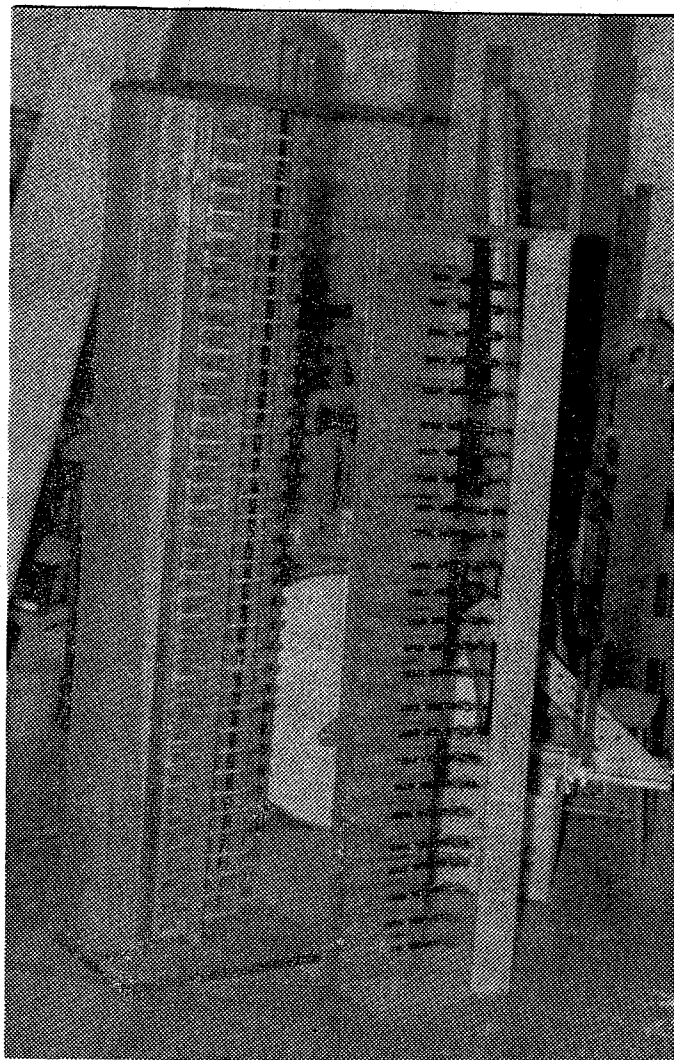

Top photo:
Solo chimes and xylophone after restoration.

Bottom photo:
The Main four rank chest after restoration.

Both of the above are waiting transport to the Orion Centre.



THE ELECTRONIC HOME ORGAN PAGE

Number 4.

By Alan DeVeax

FREQUENCY DIVIDER ORGANS

If you were to count all the frequency divider styles of electronic organs and compare them with other styles of tone generators, the frequency divider units would probably outnumber the others by ten to one!

The first practical organ to use frequency dividers was the Baldwin Model 5 which was produced in the late 1930's. Later developments included the adding of Leslie tremolo units, then transistors were used instead of valves and finally (the biggest step forward in terms of build-up of sound), two channel organs were made, which allowed one set of sounds to be diverted to the Leslie unit while other sets went to a stationary speaker.

Let us look at why frequency divider units were so widely used. The frequency of note 'A' in the middle of the keyboard is 440 cycles per second, the 'A' one octave higher is 880 cycles per second (or more correctly, 'Hertz') and the note below middle A is 220 Hertz. This relationship, that each lower note is exactly half the frequency of the one above it is the basis for frequency divider units. Electronically, this division of a wave-train by two is easy to achieve, and in addition, it is a stable process quite immune to the normal aging of valves (on which the early units were based) and easy to get going.

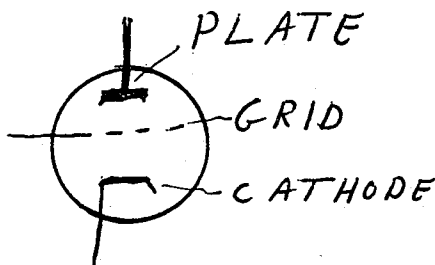

A SIMPLE VALVE

If we look at a simple electronic valve, we

find it has three basic elements. A cathode which emits electrons (negatively charged particles) which are attracted to the plate which is normally positively charged. Their way is hindered by a 'grid' - actually a loosely spaced coil which surrounds the cathode. If the grid is made slightly positive, electrons are attracted to it, but tend to be much more attracted to the more positively charged plate. Thus a current can flow from cathode to plate. However, if the grid is made negative with respect to the cathode, the electrons will be repelled and will not be able to reach the plate, so no current will flow.

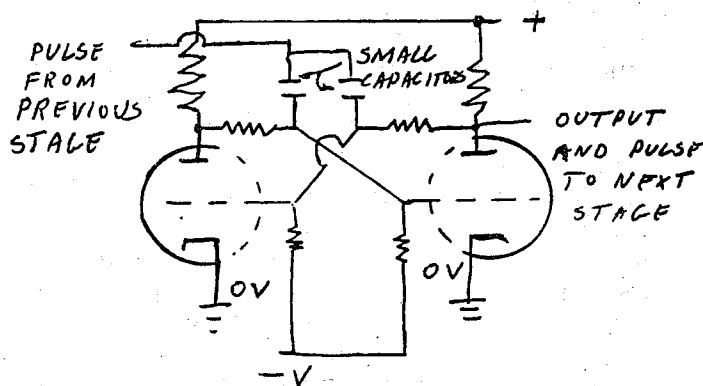

A SIMPLE DIVIDER.

A typical frequency divider consists of two simple valves (usually in the same glass envelope for convenience) connected as shown. The resistor valves are chosen so that, if the right hand side is conducting current, the reduced voltage will be passed on via the two voltage divider resistors, so that the left hand side of the valve is not conducting. The non-conducting valve will have its plate at virtually the full positive voltage and the divider from this point to the other valve grids, will ensure that it keeps conducting.

If we now introduce a positive pulse through those two small capacitors, some interesting things happen! The right hand valve is already fully conducting, so nothing will happen there, however, the positive pulse will allow the left hand valve to conduct, which will reduce the voltage at its plate, and this reduced voltage will lower the voltage on the right hand side valve grid, thereby increasing the plate voltage by reducing the current flow through the valve. The whole effect is one of rapid feedback and the circuit will change state completely so that now the left hand side is conducting and the

right hand side is cut off. Another positive pulse will change things once more. So it takes two positive pulses to change the state of the circuit once.

If these positive pulses are taken from the right hand plate of the preceding divider stage we have a perfectly good and stable frequency divider system from which all our tones (for one particular note of the scale) can be produced. Thus for a successful divider organ we need twelve 'Master Oscillators' which produce our highest notes in the scale and as many stages of frequency dividers as are necessary to produce all the tones we need.

Manufacturers soon used a packaged circuit which contained all the resistors and capacitors for convenience. Transistors work in a similar fashion and were seized upon anxiously by the Electronic Organ manufacturers. Nowadays, 'integrated circuits' containing all the parts of a frequency divider, can be obtained cheaply. Anyone wishing to make his or her own electronic organ, would do well to have a look at a typical CMOS circuit block - the 4040. At less than \$1.50 each, these units can produce twelve octaves of tone allowing us to have a full range of pitches from 16ft. to 1ft. without 'breaking back'. For more information, THE CMOS COOKBOOK by Don Lancaster is easy to read and has a wealth of pertinent information.

The very low cost of the frequency divider elements nowadays means that Electronic Organ builders should look very closely at the idea of making each manual have its own frequency divider system as this would allow a much better sound than taking all tones from one set of generators.

I LOVE A SUNBURNT TORSO

The love of city polish,
Of manners most urbane,
Of clean, pink hands and faces,
Is running in some veins,
Strong love of suit and waistcoat,
White shirts and soft silk ties,
I know - but cannot share it,
My love is otherwise.....

I love a sunburnt torso,
A chest of sweeping planes!
A man with rugged features,
And the country in his veins!
I love his skin-barked knuckles,
I love his knobbly knees;
His beauty and his terror-
It's a wide, brown man for me!

Core of my heart, my farmer!
With mud stains on his socks,
Sump oil on his moleskins,
Grass seeds in his jocks.
His pockets stuffed with hayband,
His boots caked in manure;
His constant smell of woolshed
For me holds great allure.

A tender-hearted tyrant!
A willful, stubborn man!
All you who have not loved one-
You will not understand.
Though Earth holds many splendors,
Wherever I may lie,
I know to what brown torso
My homing thoughts will fly!

With abject apologies
to Dorothea Mackellar.

NEIL JENSEN WURLITZER PIPE ORGAN POPS CONCERT

THE ORPHEUM PICTURE PALACES' STAR ORGANIST NEIL JENSEN
PULLS OUT ALL THE STOPS FOR A SPECIAL
MOTHER'S DAY PROGRAMME.
THE VARIETY PACKED PROGRAMME WILL FEATURE A KALEIDOSCOPE
OF MUSIC RANGING FROM POPULAR LIGHT CLASSICS TO
EVERGREEN MUSICAL COMEDY.

NEIL'S SPECIAL GUEST WILL BE POPULAR VOCAL PERSONALITY
MELINDA FOX.



**AVOID DISAPPOINTMENT RESERVE YOUR SEATS AT THE BOX OFFICE NOW
SUNDAY MAY 8, 1988 at 3PM.**

**HAYDEN ORPHEUM PICTURE PALACE MILITARY ROAD, CREMORNE
OPPOSITE THE METROPOLE - PHONE 908 4344**

**TICKETS \$12.00 ADULTS. \$8.50 PENSIONER/CHILD/STUDENT
THEATRE PARTY 10 OR MORE - \$10.00**

BOOKING FORM

NEIL JENSEN MOTHER'S DAY SPECIAL
KEYMEDIA PRODUCTIONS
P.O. BOX 99.
DRUMMOYNE. 2047.

Please forward me the following tickets for the NEIL JENSEN MOTHER'S DAY CONCERT to be held at HAYDEN ORPHEUM PICTURE PALACE on SUNDAY MAY 8th. 1988 commencing at 3pm.

PLEASE INCLUDE STAMPED ADDRESSED ENVELOPE

[]	ADULTS	@ \$12.00	\$ _____
[]	PENSIONER STUDENT	@ \$8.50	\$ _____
[]	THEATRE PARTY 10 OR MORE	@ \$10.00	\$ _____

Pension Benefit Card No. _____

NOTE:- PLEASE PRINT YOUR NAME AND ADDRESS CLEARLY

NAME _____

ADDRESS _____

POST CODE _____

SORRY:- NO REFUNDS ON TICKETS AFTER PURCHASE

REMEMBER - ONE CONCERT ONLY - BOOK EARLY